

Honda GX 160 Technical Regulations

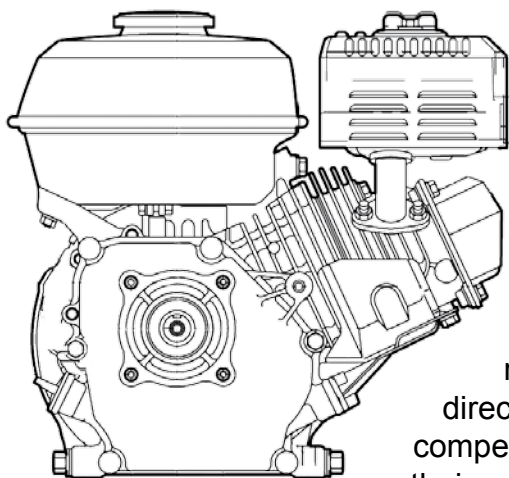

GENERAL

The scrutineer will pay special attention to ensure that the finish of all components match those of the standard unit and reserves the right to compare any part from competitors' engines directly with a standard part as supplied by Honda (UK). Unless competitors have gone out of their way to source alternative parts, their engines should automatically comply with this rule. Furthermore, competitors should note that the term "standard" refers not only to the components used but also to the number used and the manner in which the engines are assembled. Please remember that save for the changes specifically mentioned in these regulations the engines must be completely standard unmodified, and that all components will remain in place unless this document specifically states that they are allowed to be removed. No specific coating procedures are allowed on any internal or external surface of the engine. Carbon or gasket residue removal must be achieved by use of chemical agents only, to preserve original finishes. The fasteners on the engines may be drilled for the purposes of lock wiring. Replacement of external fasteners with non-Honda fasteners is only permitted when the replacement fastener improves safety or when the standard Honda fastener is not readily available. A thread recovery procedure is acceptable providing that the system and replacement fixing used are of no different size or pitch to the original and therefore offer no mechanical advantage over the original fixing.

DEFINITIONS

The standard, unmodified component

This means that the component has not had its substance altered in any way. It has had no material removed from it or added to it. It will be of the same, original material. Where appropriate, it should have the manufacturer's original manufacturing process or machining marks on it.

Engine types

The original QHQ4 engine, to engine number 7664037, shall in this document be called the K engine. The QHQ4 engine from engine number 7664037 onwards shall in this document be called the E engine. The QHQ4 engine with suffix T, from engine number 1000000 onwards shall in this document be called the T engine. This will also include all unified specification engines (GX160UT1 QHQ4), and the QHG4.

Legality limit

In general terms, and where not clarified or qualified elsewhere in this document, the legal limit for eligibility purposes shall be deemed to be the service limit as specified by Honda in the most up-to-date Honda Service manual for the particular engine. (<http://www.honda-engines-eu.com/en/welcome.html>)

COMPONENT BY COMPONENT

The fuel tank

It is strongly urged that the engine's integral fuel tank be removed. If this is done then the engine must be fitted with a suitable cover. A standard floor mounted fuel tank should then be used, unmodified and this tank and its mounting must be in accordance with chassis manufacturer's instructions or homologation. The capacity of this tank must not exceed 7.5 litres. Ballast may be added to the tank in order to maintain the maximum capacity. In this instance the kart may be fitted with a pulsed fuel pump(s), which will take a vacuum feed from either the governor rod hole or one drilled in the inlet manifold, tapped to accept a vacuum fitting. Fuel pipes must take a direct route to the carburettor and be safely secured. An extra loop of fuel pipe may be used as a return feed to the tank. One in-line fuel filter of nominal capacity per engine may be fitted.

Exhaust

The standard exhaust must be used but a unit modified and sealed by Prokart Engineering may also be used. In this case, the unit will bear a seal applied by Prokart Engineering and it is the competitor's responsibility to ensure this seal is in place at all times. At any time the modified unit on the engine can be exchanged with one held by the scrutineer, who will then send the competitor's exhaust back to Prokart Engineering for inspection. If this unit is found to have been tampered with in any way, then the competitor will be penalised retrospectively. No other repair or modification is allowed. Prokart Engineering can be contacted at 0132 928 9783 or www.prokart.co.uk. Exhaust, Part No 18310-ZH7-V90 can also be used, and modified as above.

Carburettor

There is no restriction to the use of standard, unmodified A, B or C type carburettors with any of the engine types. However all carburettors are subject to normal dimensional criteria. Overall length (manifold face to airbox face) is 54mm and bore go / no go gauge is 13.2mm / 13.3mm.

Permitted main jets

size 68 (PN 99101-ZF5-0680) size 70 (PN 99101-ZF5-0700)
size 72 (PN 99101 -ZF5-0720) size 75 (PN 99101 -ZF5-0750)

Emulsion tube can be either part number 16166-ZH8-W50 or part number 16166-ZH-810 (see drawing 1 in Appendix 1). The throttle-actuating arm can be modified to accept an actuating rod onto the throttle butterfly, a method of mounting a throttle actuating cable and a method of mounting a throttle return spring only.

Carburettor air box

Must be standard unmodified.

Air filter

Substitution or complete removal of the renewable paper/foam air filter is allowed, although the plastic outer cover must remain as standard, unmodified and fixed securely in its original position.

Spark plugs

Spark plugs fitted to the engines must be from the recommended list provided by Honda - please see below. No other spark plugs may be used. The plugs used must not be modified in any way whatsoever and must have a reach identical to that of the plugs listed. Resistor plugs will be used. The standard Honda resistor spark plug cap - as supplied with the engine - must be used.

Permitted spark plugs

| | | | | |
|-------------|---------|----------|---------|----------|
| NGK | BPR6ES | BP6ES | BP5ES | BPR5ES |
| Nippondenso | W20EP-U | W20EPR-U | W16EP-U | W16EPR-U |

Bodywork / ducting

All of the engine bodywork and ducting must be standard unmodified except for the drilling of a small hole to accept one end of a throttle return spring. The pull-cord mechanism must be standard unmodified, although the pull-cord starter may be rotated on its standard mounting holes. All or any of the bodywork / ducting can be painted or chromed.

Rocker cover

Rocker cover must be standard unmodified, although it may be painted or chromed. Its valve must be present and in working order. The breather pipe must be in position and intact, of suitable length that it is securely fixed in both the rocker cover and the outlet of the airbox, and have no perforations or leakage points.

Valve Gear

The valve rocker studs must be standard unmodified. The inlet valve collet (PN 14771-ZE1-000) may be replaced with an exhaust valve collet (PN 14773-ZE1-000) and an exhaust valve rotator (PN 14781-ZE1-000). If this modification is performed to the inlet valve, it is permissible to fit one 8mm washer between the cylinder head and the base of the valve rocker post to raise the post and ensure that the adjuster locknut sits on a full thread. The valve spring used must offer no mechanical advantage over a standard GX140 valve spring (PN14751-ZE1-000) i.e. a force of 5 kg will compress the spring to less than 25mm overall length, or a spring which offers no mechanical advantage over a standard QHG4 spring (PN 14751-ZH8-9400) i.e. a force of 8 kg will compress the spring to less than 18.5mm overall length. Valve rockers, cam followers and pushrods must be standard unmodified.

Valves

Valves will be standard unmodified. Valve-seat grinding and cutting is allowed, to standard profiles (including seat width) as specified in the latest Honda manual for the engine type.

Cylinder head

Will be standard unmodified and measure a minimum of 73.98mm from the rocker cover gasket face to the cylinder head gasket face. Ports must be standard unmodified. The standard de-burring marks and sharp edges should always be present. A maximum measurement of 29.25mm (inlet) and 28.25mm (exhaust) must be present between the cylinder head gasket face and the land surrounding the valve guide (see drawing 4 in appendix 1)

Head gasket

Must be standard unmodified and will at all times have a minimum thickness at all points of 1mm.

Piston

The dished piston must only be used with the cylinder head from the K type engine. The flat-top pistons are interchangeable between the E and T type engines only and must not be used in the K type engine or with the K type head. Piston rings will be standard unmodified. Only standard size rings, marked R, T or N can be used. Either the single or three-piece oil control ring can be used on all engine types. The rings must always be free in their grooves to function as designed.

Connecting Rod

The standard unmodified unit is interchangeable between all engine types.

Crankshaft

The governor gear can be removed. The position of the cam gear wheel is free. The standard key must be used. The crankshafts are different between engine types but are interchangeable between all engine types.

Flywheel

The flywheel will be standard unmodified and is interchangeable between all engine types. It must have a minimum weight of 2.35kgs. The standard unmodified fan must be used, with all fins in place.

Ignition coil

The ignition coil (including ignition lead and plug cap) will be the standard unmodified unit and is interchangeable between all engine types. The coil mounting bolts must be standard unmodified and use the original mounting positions.

Camshaft

The standard unmodified camshaft must be used, which is interchangeable between all engine types. The service limits are 13.916mm for the journals and 27.65mm for the exhaust and 27.60mm for the inlet lobes.

Crankcase

The crankcase can only be modified by the removal of the governor mechanism and in all other respects must be standard unmodified. If completely removed, the hole in the crankcase must be sealed to prevent oil leakage (unless a suitable pulse take-off is used). The crankcase bearings and seals must be standard unmodified. The bore must be standard only, service limit 68.165mm at all points of the bore. No sleeving or surface material change to the cylinder bore is allowed but honing is permitted. The cylinder mating face must always have the manufacturer's original finishing marks visible. The deck height must be 45.15mm \pm 0.2mm (read between the cylinder mating face and the cast face of the piston, in line with the piston pin, with the piston at BDC). Carbon removal is allowed as describe previously. (See drawing 2 & 3 in Appendix 1).

When measuring a K type engine, 1.3mm should be added to the obtained reading, to accommodate the dish in the piston.

Crankcase side cover

must be standard unmodified and positioned with both standard dowels in place.

Gaskets

All gaskets must be standard unmodified. Where there is any doubt about the eligibility or suitability of a particular gasket it should be compared with a new item from the manufacturer.

Clutch

A dry, air-cooled centrifugal clutch of Noram, Horstman, Magnum, Maxtorque 1600 or 4000 series type (or any other clutch subsequently introduced which satisfies the same criteria), must be used to transmit the drive. The clutch should be in standard form (as supplied), be incapable of adjustment in position and have a maximum engagement speed of no more than 2,500 rpm engine speed.

Appendix 1

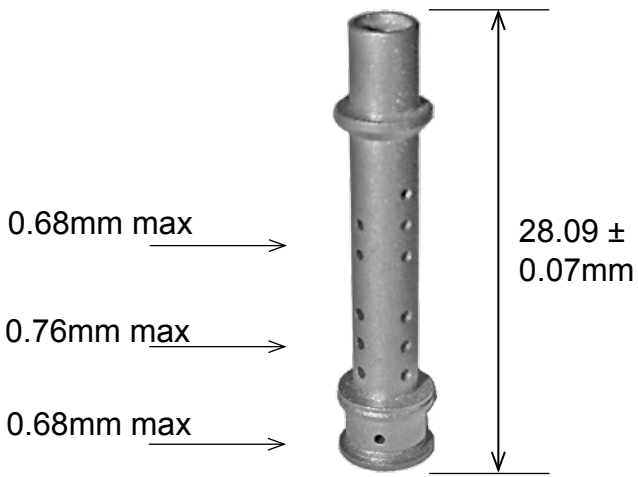

Major bore 1.95mm max
PN 16166-ZH8-W50

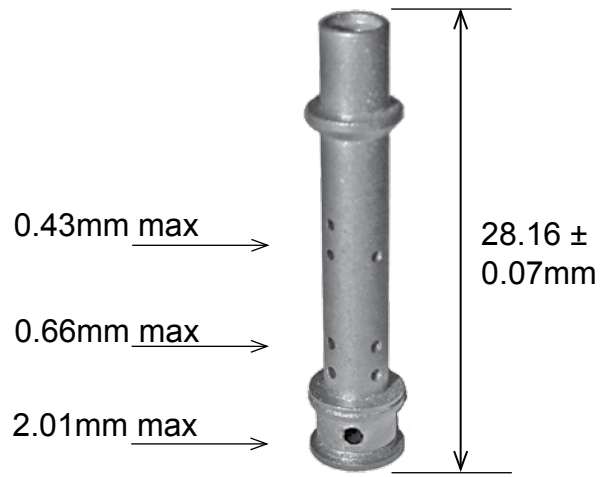

Major bore 1.85mm max
PN 16166-ZH8-810

Drawing 1

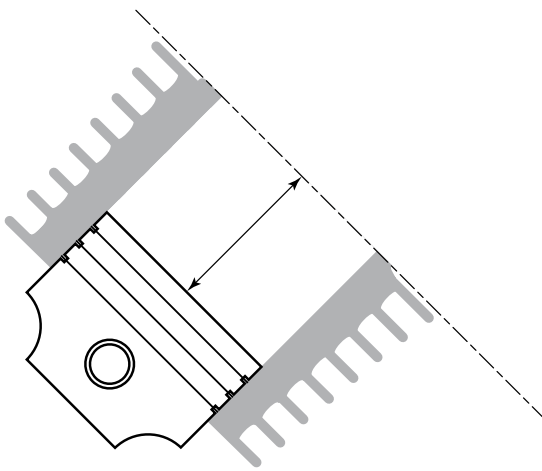

Drawing 2



Drawing 3

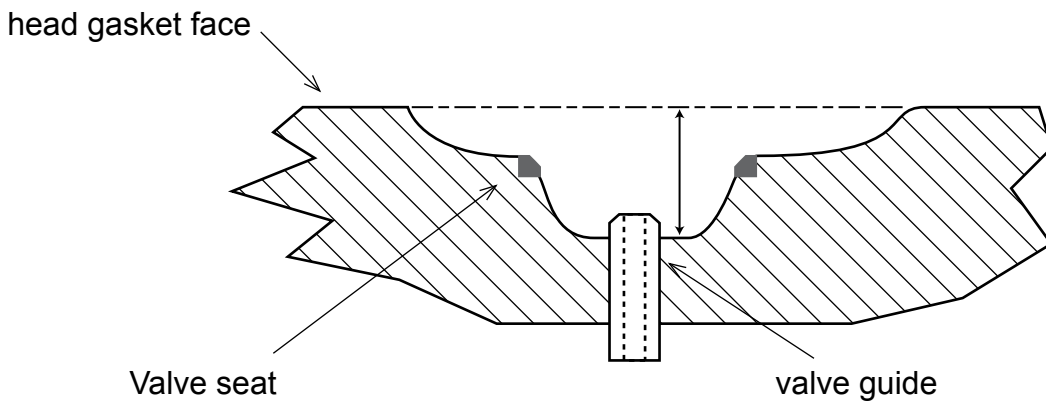

Drawing 4